

49th ANNIVERSARY

The Coulee Region's Design/Build Leader Since 1970

EXCLUSIVE OFFER IN HONOR OF BRICKL BROS.' 49TH ANNIVERSARY!

\$49,000 + 4.9% OFF*

*4.9% is applied to the first \$49,000

40'X 48'X14" BUILT ON CONCRETE FOUNDATION AND SLAB

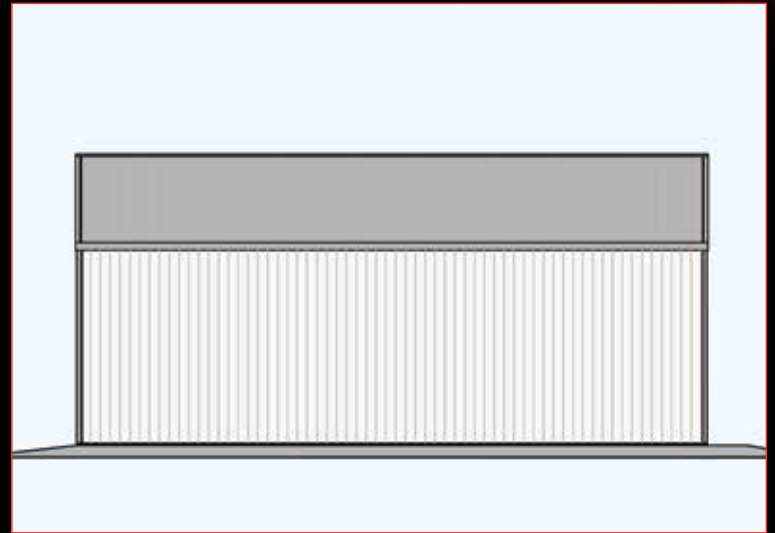
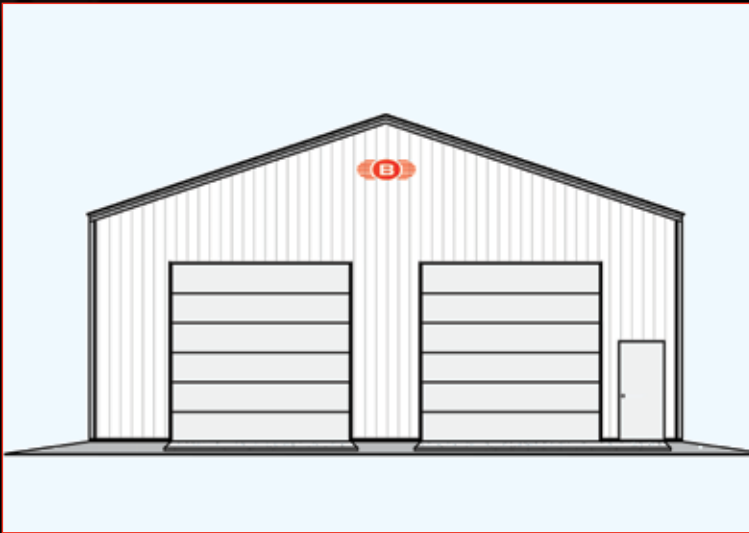

- Non-Insulated 18"x18" Grade Beam
- 5" Reinforced Concrete Floor
- Floor Sealer, and Saw Cut
- 4'0" O.C. 2X6 Ladder Frame Walls
- 29 Gauge 80,000 PSI Colored Steel
- 4'0" O.C. Trusses with 2x4 Purlins
- Standard Colored Eave and Rake Trims

- Continuous Vented Ridge
- Attic Access Door
- Insulated 3068 Service Door
- Two (2) 12'0"x12'0" Insulated Overheads with Operators
- Multi-Storage Building
- Fabric Ceiling (Non-Insulated)
- Upgrade Above Overheads to a smooth FRP panel Liner



BRICKL BROS.

Designers | Construction Managers | Builders

400 Brickl Road | West Salem, WI 54669

Toll Free: (800) 658-9030 | www.BricklBros.com

CONTACT YOUR BRICKL BROS. REPRESENTATIVE TO GET STARTED!

(866) 437-4022 or
[www.BRICKL49.com!](http://www.BRICKL49.com)

49th
ANNIVERSARY

EXCLUSIVE OFFER!

\$49,000 + 4.9% OFF*

*4.9% is applied to the first \$49,000

40'X 48'X14" BUILT ON CONCRETE FOUNDATION AND SLAB

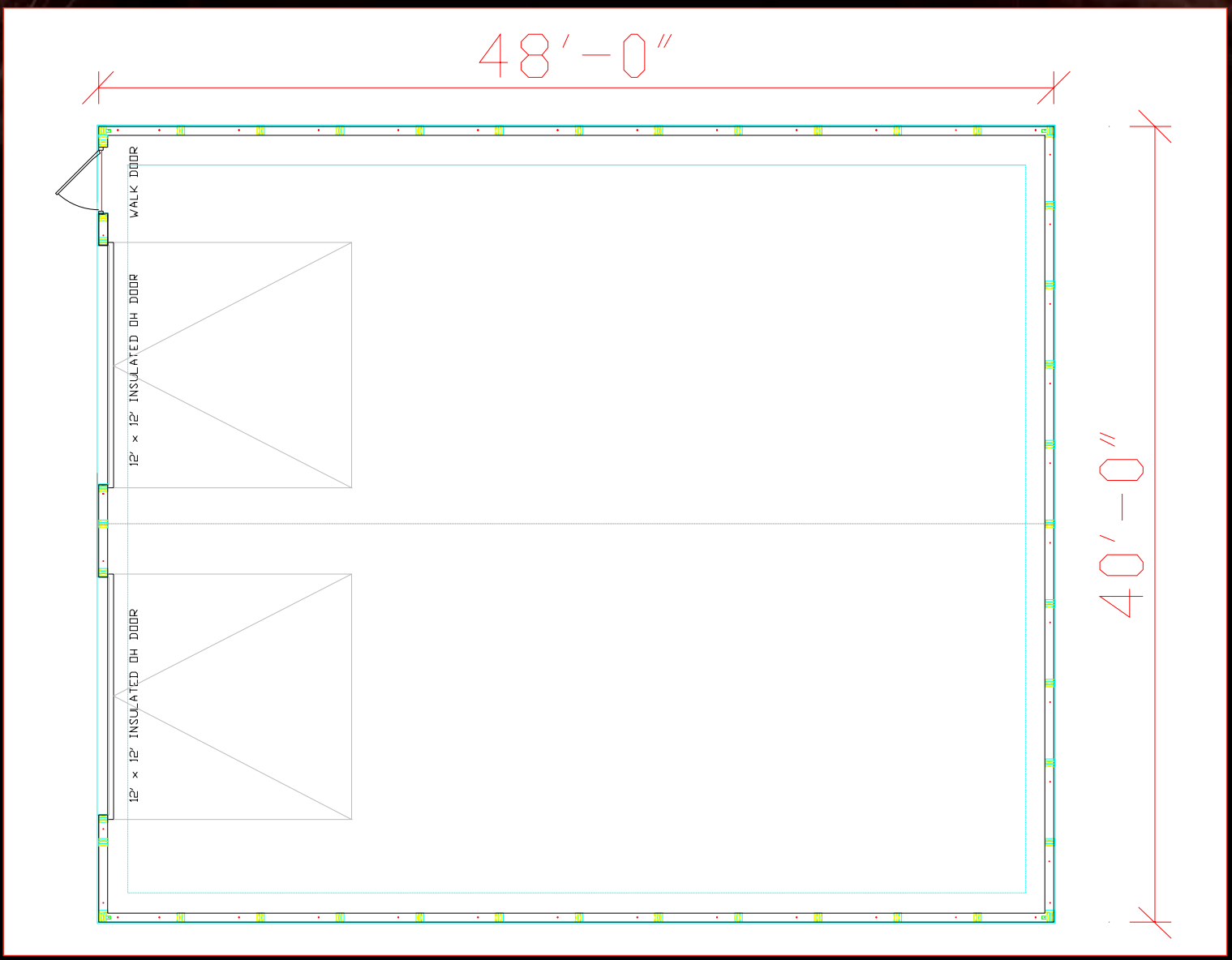

BRICKL BROS.

Designers | Construction Managers | Builders

400 Brickl Road | West Salem, WI 54669

Toll Free: (800) 658-9030 | www.BricklBros.com

**CONTACT YOUR BRICKL BROS.
REPRESENTATIVE TO GET STARTED!**

**(866) 437-4022 or
[www.BRICKL49.com!](http://www.BRICKL49.com)**